

COMBi-OP ORDER PICKER

The Combi-OP is a safe robust work platform for efficient processing of multiple orders and long loads.

COMBiLiFT

LIFTING INNOVATION

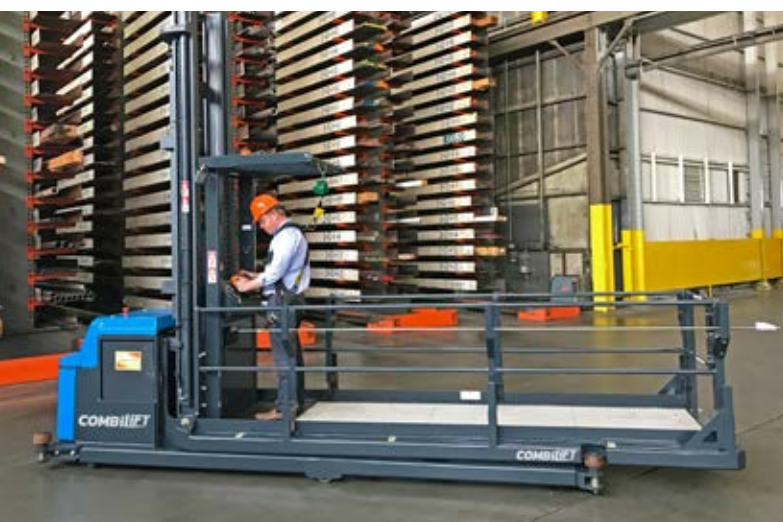

COMBI-OP ORDER PICKER

SIDE VIEW

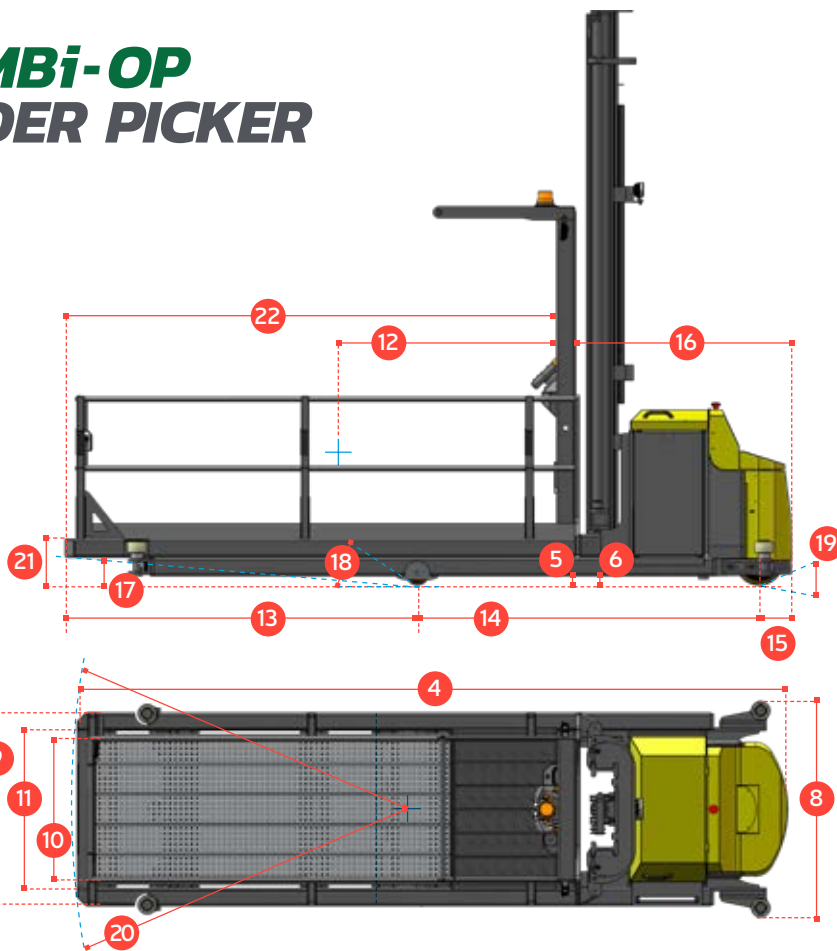

PLAN VIEW

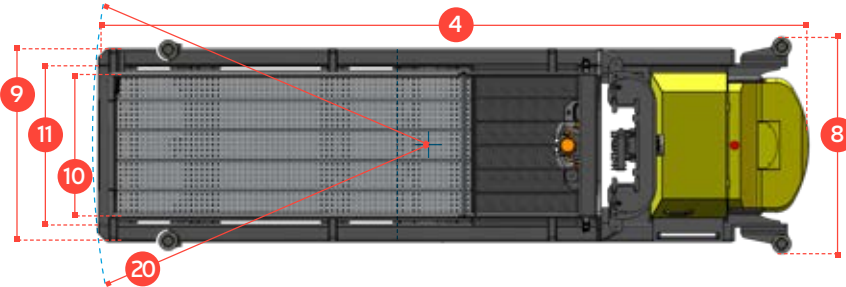

FRONT VIEW

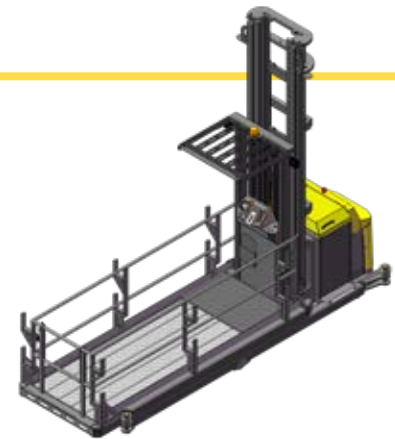
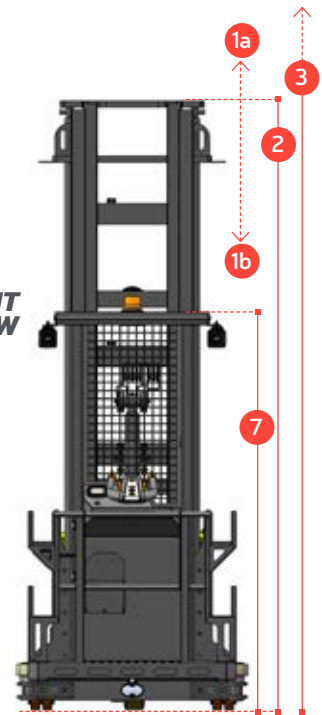

REF.	DESCRIPTION	STANDARD
1a	Standard Lift Height	6000 mm
1b	Free Lift Height	1270 mm
2	Height Mast Closed	3760 mm
3	Mast Raised	8500 mm
4	Overall Length	4725 mm
5	Ground Clearance Under Mast	57 mm
6	Ground Clearance to Centre of Wheelbase	57 mm
7	Height Over Guard	2490 mm
8	Width Across Rollers	1435 mm
9	Platform Outer Width	1285 mm
10	Platform Inner Width	902 mm
11	Track Front	1118 mm
12	Load Centre Distance	1320 mm
13	Overhang Front	2286 mm
14	Wheelbase	2210 mm
15	Overhang Back	216 mm
16	Length from Face of Platform	1525 mm
17	Approach Angle	1½°
18	Ramp Angle	6°
19	Departure Angle	20°
20	Turning Radius	2795 mm
21	Platform Height	305 mm
22	Platform Length	3188 mm
A	Capacity	500 kg
B	Unladen Weight (No Battery)	4036 kg
C	Maximum Ground Speed	10 kph
D	Gradeability	2%
E	AC Rear Drive	4 kw
F	AC Pump Motor	5 kw
G	Battery	48 V x 700 Ah
H	Vulkollan Front Tyre x 4	OD 6" / Width 2"
I	Vulkollan Rear Tyre	OD 12" / Width 5"
J	Standard Colour	Yellow & Grey

Features Include:

- Standing Operator Over-Head Guard
- Multi-function Steering/Function Console
- Platform End Entry/Exit Gate
- Dual Speed Control
- AC Electric Steering
- Operators Display
- AC Motor Technology
- Guide Rollers
- LED Work-lights

Distributed by:

COMBILIFT HAS A POLICY OF CONTINUOUS PRODUCT DEVELOPMENT AND RESERVES THE RIGHT TO ALTER SPECIFICATIONS WITHOUT PRIOR NOTICE. SPECIFICATIONS AND/OR DIMENSIONS MAY VARY FROM THOSE ILLUSTRATED IN SOME COUNTRIES.