

COMBi-SC8-3 High



COMBI-SC8-3 HIGH

COMBILIFT
LIFTING INNOVATION

Advantages:

- Capable of lifting 20', 30', 40', 45' Containers
- Independent Sideshift for easy placement of containers
- Easy access cab, Raised for optimum viewing of all operations
- Ergonomic Fingertip controls
- Guided spreader to eliminate load swaying
- Multiview camera system for extra visibility when working in narrow aisles
- Engine Bay and Hydraulic Compartment at ground level for ease of Service
- Access platform of easy maintenance and inspection
- 8-wheel design for low ground pressure
- 4 steering modes for increased manoeuvrability
- Combi Connect Telematics system included for real-time factory support

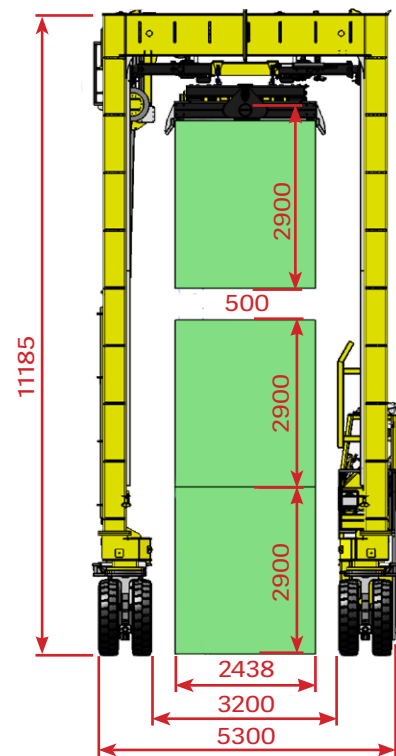
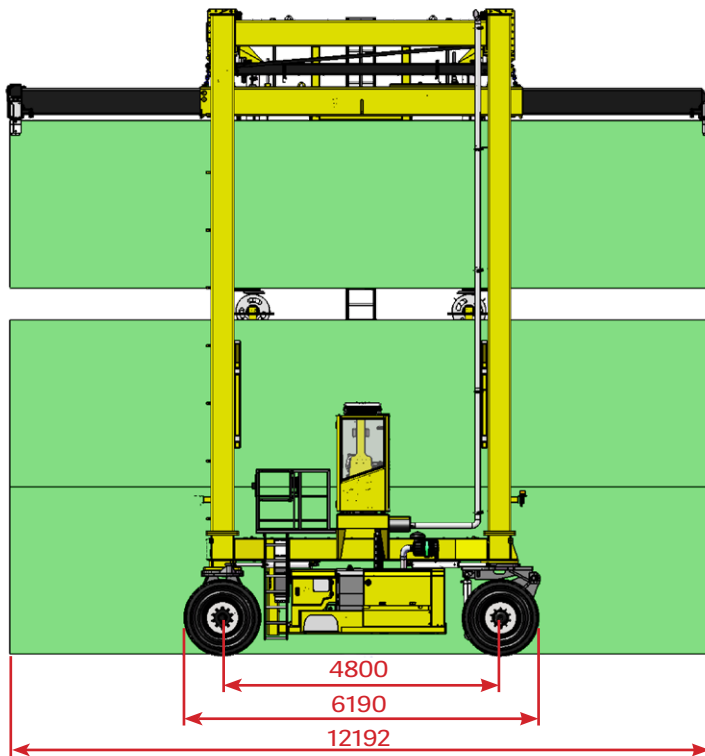
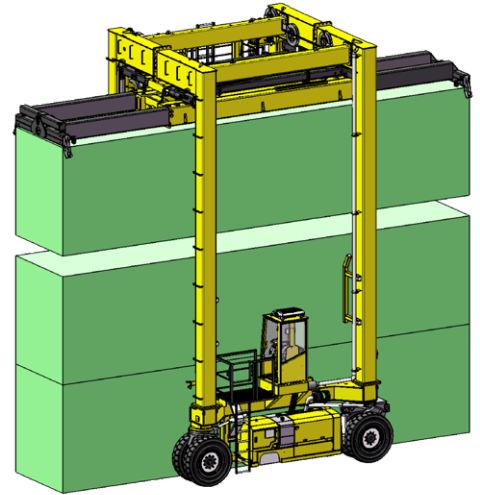

Technical Specification:

- 2 Wheel Drive
- 2 Wheel Brake
- All Wheel Steer
- 14.00x24 Solid Tyres Dual Wheel Assemblies
- Active Hydraulic Suspension
- 125Hp Diesel Engine
- 400mm Independent Front & Rear Sideshift
- Fully Automatic 20-40 Toplift Attachment
- Fully Enclosed Operator Cabin, includes heater and Aircon
- 10 km/h ground speed
- 6.8m Lift Stroke
- 4m/min Lift Speed when Fully Laden
- 6m/min Lift Speed when Empty
- 6m/min Lowering Speed

R74 50
With 40ft
Container

R6150
With 20ft
Container

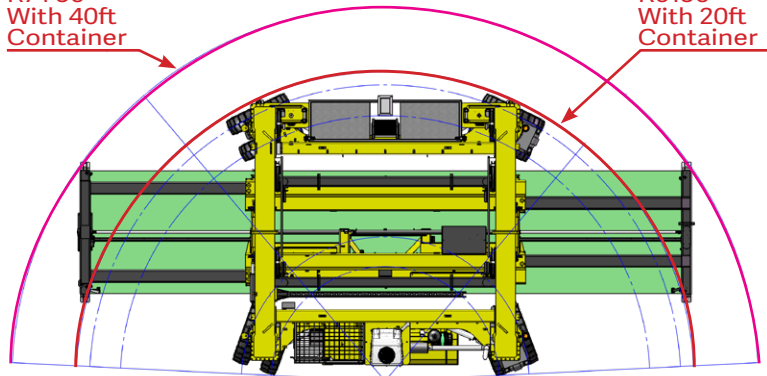

combilift.com