

COMBiLiFT
LIFTING INNOVATION

C-SERIES

C3000ET - C5000ET

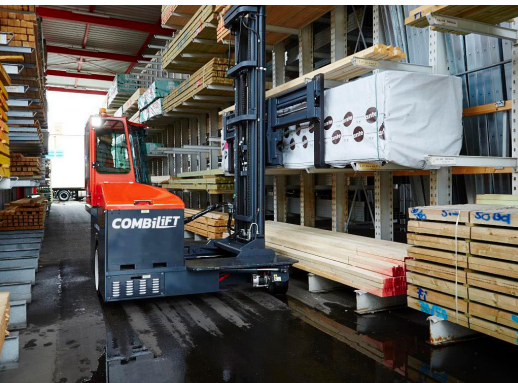

The electric multi-directional forklift designed for the safe, space saving and productive handling of long and bulky loads.

combilift.com

C3000ET - C5000ET

FRONTAL MODE

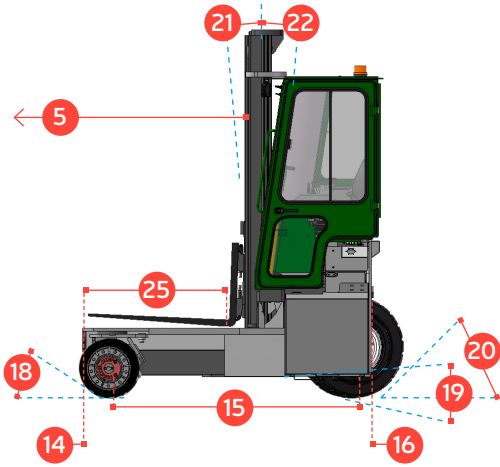

SIWARD MODE

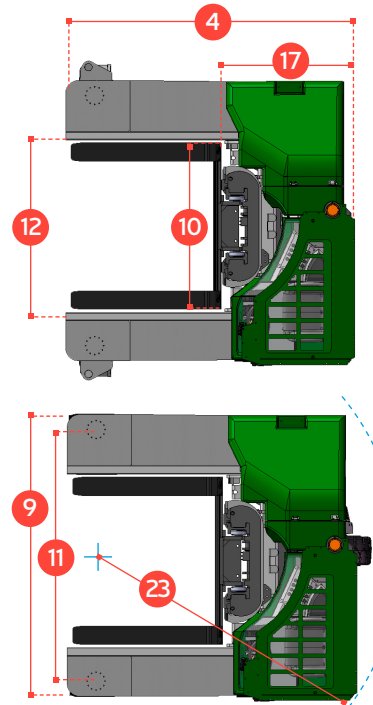
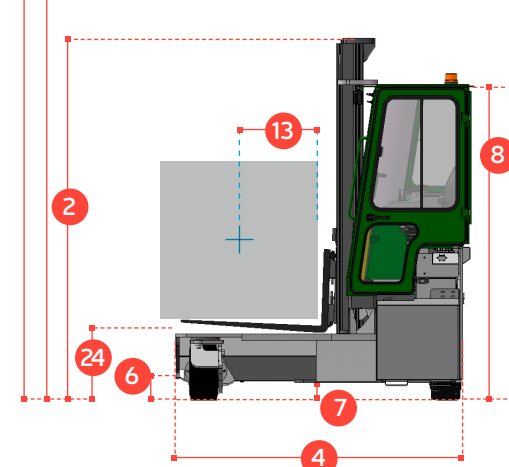

Ref	Description	C3000ET	C4000ET	C5000ET
1a	Max. Lift Height		4040 mm	
1b	Freelift Height		0 mm	
2	Height Mast		2,915 mm	
3	Max. (Mast raised)		4,930 mm	
4	Overall Length	1950mm	2300mm	2500mm
5	Mast Travel	950mm	1300mm	1450mm
6	Ground Clearance Under Mast		155 mm	
7	Ground Clearance to Centre of Wheelbase		200 mm	
8	Height Over Cab (Without work lights)		2500 mm	
9	Width		2275 mm	
10	Outside Spread of Fork Arms		1350 mm	
11	Track Front		2030 mm	
12	Frame Opening		1400 mm	
13	Load Centre Distance	450 mm	600 mm	600 mm
14	Overhang Front		245 mm	
15	Wheelbase	1545 mm	1895 mm	2045 mm
16	Overhang Back		135 mm	
17	Length From Face of Fork	1100 mm	1100 mm	1150 mm
18	Approach Angle		45°	
19	Ramp Angle		17°	
20	Departure Angle		45°	
21	Forward Tilt		3°	
22	Backward Tilt		5°	
23	Minimum Outside Radius	2235 mm	2310 mm	2490 mm
24	Platform Height		545 mm	
25	Platform Length	850 mm	1200 mm	1350 mm
A	Capacity	3000 kg	4000 kg	5000 kg
B	Unladen Weight	6300 kg	6650 kg	6850 kg
C	Maximum Ground Speed		10km/h	
D	Gradeability		10%	
E	Battery Capacity (V / Ah)		80V / 620Ah	
F	Fork Section	50mm x 150mm x 850mm	50mm x 150mm x 1200mm	50mm x 150mm x 1350mm
G	18 x 9 - 12 Front Tyre		OD 457mm / Width 305mm	
H	27 x 10 - 12 Rear Tyre		OD 680mm / Width 255mm	
I	Standard Colour		Green & Grey	
J	AC Electric Traction Motor x 2		80v / 5kW	
k	AC Electric Pump Motor		80V / 19kW	

Multi-Directional

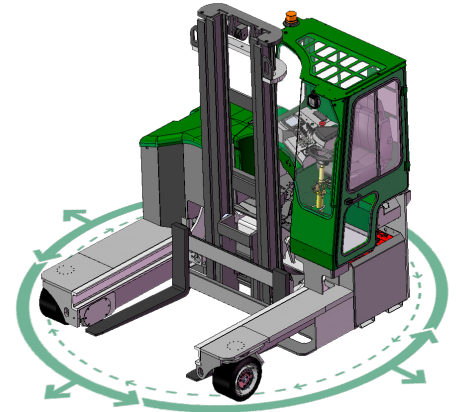

Features Include:

- Rubber Mounted Cabin
- AC Motor Technology
- Multi-Direction Operation
- Load Sensing Steering
- Curtis AC Software
- 4 Way Lever Positioning of Wheels
- 3 Wheel Drive

Distributed by:

International Patent Application No. PCT/EP2014/053066; UK Patent Application No. GB 1302811.3

CO. MONAGHAN +353 47 80500
IRELAND INFO@COMBILIFT.COM

combilift.com

COMBILIFT HAS A POLICY OF CONTINUOUS PRODUCT DEVELOPMENT AND RESERVES THE RIGHT TO ALTER SPECIFICATIONS WITHOUT PRIOR NOTICE. SPECIFICATIONS AND/OR DIMENSIONS MAY VARY FROM THOSE ILLUSTRATED IN SOME COUNTRIES.